

Specifications

Model	HZY-10B (P620)	HZY-10B (P650)
Purpose	Disease control centers, hospitals, etc. are used for transport of infectious substance specimens (air transportation)	Disease control centers, hospitals, etc. are used for transshipment of Class B infectious substance specimens (air transportation)
Type	Passive cooling	Passive cooling
Internal dimensions (W * D * H mm)	345*225*182	345*225*182
External dimensions (W * D * H mm)	430*312*272	430*312*272
Loading quantity	2 transport tanks	2 transport tanks
Effective volume	14L with 2 built-in specimen sealed tanks	14L with 2 built-in specimen sealed tanks
Specimen sealed tank size (mm)	H160 * D130	H160 * D130
Number of test tubes (Single tank)	16 test tubes D10 (small), 2 test tubes D15 (large)	16 test tubes D10 (small), 2 test tubes D15 (large)
Net weight (kg)	8	4
Transport temperature (°C)	2-10	2-10
Thermal insulation time (32°C full load) (h)	8	7
Cabinet material	Aluminum magnesium alloy box shell	PP plastic
Thermal insulation material	EPP foam liner	EPP foam liner
Cool storage mode	PCM ice pack cold storage	PCM ice pack cold storage

Transport Cooler for Infectious Materials

— Transfer Scheme for 2019-nCoV Specimen

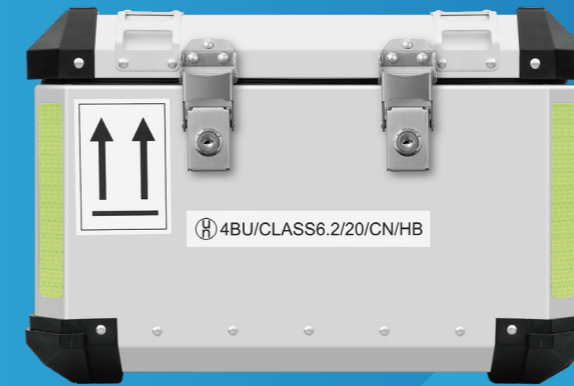

HZY-10B

Scope of Application :

Due to the Outbreak of COVID-19, rapid transport of samples became a focus. The virus is a high-risk specimen, and if there is a collision during the transportation or transmission, there will be a risk of leakage and re-infection.

A solution was urgently needed to ensure the viability of the samples and the safety of transport personnel; this is the solution.

Exclusive Advantage

As the leading manufacturer of high-risk specimen transport containers, Haier Biomedical is the only manufacturer who was selected for the Equipment Catalog in China as the transport solution that was urgently needed with the current situation of the out- break of COVID-19.



Product Requirements

Requirements for the transport container of highly pathogenic microorganisms (toxins) or samples (briefing)

- In the transportation of highly pathogenic microorganisms, it is required to adopt a three-layer packaging system: **the main container, auxiliary container and outer package from the inside to the outside.**
- The highly pathogenic microorganism specimens or samples shall be properly stored in the main container, which shall be sterile, impermeable and leakproof. The main container may be made of glass, metal or plastic and necessarily with a reliable leak-proof seal, such as heat seal, flange stopper or metal coiled-edge seal. Wrapping the main container with enough sample absorbent material to absorb all the samples in case of leakage.
- The auxiliary container is a strong, waterproof and leakproof container which outside the main container. Its function is to package and protect the main container. When multiple primary containers are loaded into a secondary container, they must be wrapped separately to prevent contact with each other and lined with adequate absorption material. Relevant documents (such as sample quantity forms, hazard statements, letters, sample identification information, sender and recipient information) should be placed in a waterproof bag and posted on the outside of the auxiliary container. Auxiliary container must be secured within the outer packing with appropriate liner material to protect itself.
- The main and auxiliary containers shall be kept intact with the temperature at which the refrigerant is used and at the temperature and pressure that may occur after the loss of refrigeration. **The primary and secondary containers must be able to withstand 95kPa of internal pressure without leakage and be able to withstand damage at temperatures ranging from -40°C to + 55°C.**
- The outer packing is a protective layer on the outer surface of the auxiliary container. The outer packing has sufficient strength and shall be affixed with uniform marks on the outer surface as required.

Packaging System

Three-layer packaging:

- Main container**
Test tube with cap (user configures according to business)
- Auxiliary container**
≥95kPa pressure sealed tank (EPS or EPE bracket for fixing test tube, 16 hole D10 test tube + 2 hole D15 test tube)
- Outer packaging**
Transfer box (ice row, foam used to fix sealed container, activated carbon and other adsorbed substances, sample labeling)

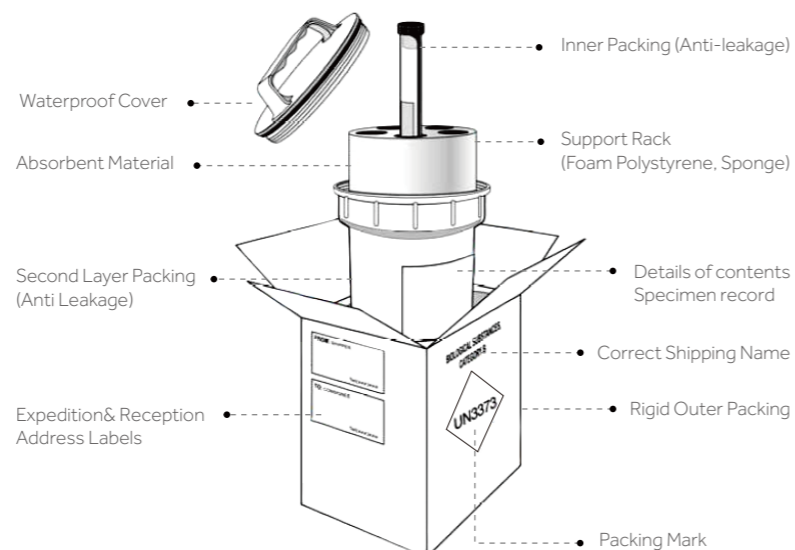

Product Advantages

UN2814 transport cooler

- Passive cooling, long preservation time, suitable for air transportation**
At 32°C ambient temperature, the temperature in the container (pre-cooled in advance) rises to 10°C+ takes 8 hours.
- PCM ice row, frozen at 4°C, to ensure the safety of specimen storage**
- The shell is made of aluminum-magnesium alloy, with high strength; it meets the PI620 packaging requirements of Class A infectious substances.**

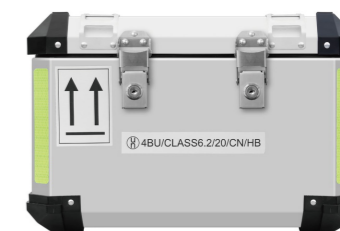

HZY-10B (P620)

UN3373 transport cooler

- Passive cooling, long heat preservation time, suitable for air transportation**
At 32°C ambient temperature, the temperature inside the box (pre-cooled in advance) rises to 10°C+ takes 7 hours.
- PCM ice row, frozen at 4°C, to ensure the safety of specimen storage;**
- The shell is made of aluminum-magnesium alloy, with high strength; it meets the PI620 packaging requirements of Class A infectious substances.**



HZY-10B (P650)

Transport Cooler - Auxiliary Container

HZY-10B (P620)



HZY-10B (P650)



Pressure sealed tank (EPS or EPE holder for fixing test tubes, 16-hole D10 test tube + 2-hole D15 test tube)

The pressure-sealed tank remains intact at the temperature of the refrigerant used, as well as the temperature and pressure that may occur after loss of refrigeration. Under the condition of no leakage, it can withstand the internal pressure of 95kPa, and can ensure that it will not be damaged in the temperature range of -40°C to + 55°C.